OPERATOR & MAINTENANCE MANUAL

Steffen Systems Bale Accumulators



Manufactured by Steffen Systems
2882 Howell Prairie Road Northeast
Salem, Oregon 97305 USA
Phone 503-399-9941 Fax 503-371-4779
www.steffensystems.com



1. MACHINE DESCRIPTION	4
2. WARRANTY	5
3. SAFETY RULES	6
4. OPERATORS INSTRUCTIONS	7
4.1 System Objective	7
5. EMERGENCY STOP	8
6. MAINTENANCE & SERVICING	8
6.1 Service Schedule.	9
6.1.1 Every 2000 bales	9
6.1.2 First 2000 bales, then thereafter every season	9
6.2 Adjustments	9
7. TECHNICAL INFORMATION.	10
7.1 Machine Specifications.	10
7.2 Setup Instructions	11
7.3 Installation Photos	12
7.3.1 Hitch Installation Drawing	13
7.4 Hydraulic Circuit	14
7.5 Wheel Clutch Assembly Drawing	15
7.6 Electrical Circuits	16
7.6.1 Model 850/1050/1250/1550/2250	16
7.6.2 Model 950	17
7.7 Parts List	18
7.8 Fault Finding	25
7.8.1 Feed chain does not rotate	25
7.8.2 Pushbar or tiebar does not activate properly	25
7.8.3 Tiebar does not activate after dumping	26
7.8.4 Tie bales catch far side of accumulator	26
7.8.5 Accumulator tires to dump with partial package	26
7.8.6 Accumulator does not dump	26
7.8.7 Dump chain doesn't stop after unloading	26
7.8.8 Bales fall out of the rear of the machine	27
7.8.9 Everything is stalled	27
7.8.10 Wheel clutch, tie bar or push bar extends by itself and locks	27
7.8.11 Wheel clutch, tie bar or push bar "floats" out of position	27
7.8.12 Bales get cut in half by push bar	28
7.8.13 Bales get caught in throat when turning	28
7.8.14 Bales slide around in accumulator	28
7.8.15 Tie bales roll on their sides when dumped	28
7.8.16 Tie bar extends and stays	28

7.8.17	All functions move but have no power	28
7.8.18	Other helpful items to check	29
8.	PLANT SAFETY ASSESSMENT & EVALUATION	30
8.1	Hazard Identification Checklist	30
8.2	Risk Assessment Table	33
8.3	Hazard Identification, Risk Assessment, Control and Revision	33
8.4	Hazard Identification	35
8.4.1	Hitch Point	35
8.4.2	Feed Chain	36
8.4.3	Feed Motor	36
8.4.4	Tie Arm	37
8.4.5	Hydraulic Cylinder	37
8.4.6	Push Arm	38
8.4.7	Hydraulic Cylinder	38
8.4.8	Retracting Push Arm	39
8.4.9	Dump Clutch	39
8.4.10	Drive Chain	40
8.4.11	Dump Chains	40
8.4.12	Dump Bar	41
8.4.13	Tires	41
9.	MACHINE SAFETY REVISION	42
10.	TRAINING NOTES	43
11.	APPENDICES	44

This manual must be read in conjunction with the manuals that are supplied with the tractor and baler to which the bale accumulator is attached.

1. MACHINE DESCRIPTION

The Steffen System bale accumulator is a hydraulic powered electronically controlled, automated piece of farm equipment that tows behind a standard hay baler to group bales of hay together and place the group on the ground.



2. WARRANTY

Limited Express Warranty

Your new bale accumulator carries a limited warranty against defects in materials and workmanship for a period of Twelve (12) months from the date of delivery.

This warranty does not apply to any unit or system or component which has been improperly installed, handled, abused, damaged in an accident, nor to any unit or system or component which has been repaired or altered by unauthorized personnel.

This warranty also does not apply if the equipment has not been used in accordance with the operator & maintenance manual supplied.

The warranty does not cover physical damage or deterioration due to normal wear and tear, nor are consumables such as hoses, chains, bearings etc covered.

Accurate records of all inspections, maintenance and servicing must be kept. Failure to comply will void warranty.

Warranty of proprietary branded equipment is the responsibility of the original equipment manufacturer (OEM).

Under no circumstances will the Owner be entitled to consequential or incidental damages. No responsibility will be taken for any other damage, inconvenience or other claims whatsoever.

Our liability under this warranty is limited to the repair and or replacement of the defect or defective part.

All warranty work on your bale accumulator will be performed at our workshop or by an authorized agent by mutual agreement. Labor is generally not covered in the event of a warranty claim.

3. SAFETY RULES

READ THE INSTRUCTIONS IN THIS MANUAL IN CONJUNCTION WITH OTHER RELEVANT EQUIPMENT INSTRUCTIONS.

There is no occasion in which this machine requires a person to be in contact with any portion of it while the power is on and the machine is operating. Any part of this machine could cause bodily harm, injury or death at any time it is in operation.

WARNING: RISK OF SEVERE PERSONAL INJURY OR DEATH

Do not attempt any type of maintenance or adjustment to this machine while it is in operation, or while the power is on. Turn off all hydraulics and electrical control prior to performing work.

- Read the operator and maintenance manual supplied with the machine.
- All safety procedures must be followed.
- All operation and maintenance requirements must be adhered to.
- Do not use this equipment for a purpose other than that for which it was designed.
- Do not attempt to operate, if guards are removed, if the machine is in an unsafe or defective condition.
- Safety guards are not to be tampered with or removed by the operator.
- Maintenance to be carried out only after the machine has been turned off, park brake applied, battery isolated, and all moving parts are in the rest or lowered position.
- Only trained and approved personnel are to operate this equipment.
- Operator must not start machine unless all personnel have been accounted for and warned.
- The operator must not operate the bale accumulator unless the area around the machine is clear of unnecessary personnel and equipment (15 feet nominal clearance).
- No passengers are to be carried on this attachment.
- The bale accumulator must not be used to transport bales on public roads.

WARNING : FIRE RISK.

Poor housekeeping, cleaning and/or inadequate maintenance and inspection of this equipment could lead to a fire. Daily inspections are necessary.

WARNING : ENGINE EXHAUST FUMES ARE POTENTIALLY DANGEROUS.

This machine must only be used in a well-ventilated area above the ground.

WARNING : FLUIDS UNDER HIGH PRESSURE ARE POTENTIALLY DANGEROUS IF A LEAK OR HOSE DETACHMENT SUDDENLY OCCURS.

Fluids under pressure have sufficient force to penetrate the skin, causing serious personal injury. If injured by escaping fluid, obtain medical assistance at once. Serious infection can develop if medical treatment is not administered immediately.

4. OPERATORS INSTRUCTIONS

4.1 System Objective

Sequence of events:

As bales leave the baler, the feed chain on the accumulator pulls them away so as to keep the baler from forcing bales into the accumulator. The rubber cords on either side keep the leading corners of the bales turned into the throat as the baler turns corners. As the bales enter the machine, the bale clear loop switch is held on by the bale which in turn disables the trip switch in the rear. This is done so that the bales must fully enter into the boxed area before pushing them over. This keeps the pusher bar from cutting the bales in two.

Once the first two bales enter the box area, trigger the trip switch, and release the bale clear switch, the feed chain stops, and the tie bar (Model 950 only) sweeps them 90 degrees to the rear of the machine and moves the dump bar to the rear corner of the box area. (All other models skip this portion and go directly to pushing straight). This dump bar now is acting as a tailgate to keep the bales in the box area.

Once the tie bar is fully extended, the tie bar limit switch is flipped out, which tells the tie bar to retract. When the tie bar switch is flipped back to the home position, it turns on the feed chain and deactivates the select relay which in turn changes the electronics to straight push mode.

The next two bales come with the same procedure, and the push bar extends this time rather than the tie bar. When the push bar is fully extended, the push bar limit switch is flipped over, which sends the push bar back to its home position. When the push bar is nearly home, the push bar limit switch is flipped back, which turns on the feed chain again. This continues until the box area is full. When the box area is full, the push bar attempts to push but cannot move and builds pressure.

When this pressure exceeds the setting of the pressure switch (generally around 1500 psi) the pressure switch engages which releases the push bar and engages the wheel clutch. As the wheel clutch engages, the dump chain pushes the bales out onto the ground at a slightly faster rate than the ground speed. As the dump bar comes around, it trips the dump stop switch, which disengages the wheel clutch, and resets the electronics to go to the tie bar mode (Model 950 only).

Once this is completed, the cycle is complete and ready for the next group of bales.

5. EMERGENCY STOP

If there is an accident, or the machine malfunctions stop the machine by turning the ignition key to the 'off' position, and apply the tractor park brake. In addition, turn off the "Power" toggle switch in the main control box in the cab of the tractor, or on the accumulator.

Rectify any problems before re-starting machine.

6. MAINTENANCE & SERVICING

ACCURATE RECORDS OF ALL INSPECTIONS, MAINTENANCE AND SERVICING MUST BE KEPT. Failure to comply will void warranty.

WARNING: LOCKOUT UNIT BEFORE STARTING ANY REPAIR WORK

Maintenance to be carried out only after the tractor has been turned off, park brake applied, battery isolated, and all moving parts are in the rest or lowered position.

Prior to any hydraulic maintenance work, lower all moving functions to the rest position, fit safety props or links and with the engine turned off operate all controls to remove all system pressure.

When hydraulic components are refitted after repair or replacement they will contain air. This affected component will be difficult to control until the air is bled from the system. To bleed the air run the tractor at an idle and without a load operate the function full stroke in either direction several times. Stop the tractor and check for hydraulic leaks.

For best performance keep this machine clean and properly maintained.

6.1 Service Schedule.

6.1.1 Every 2000 bales:

1. Grease push bar pivots, 4 points.
2. Grease tie bar pivot 1 point (Model 950 only)
3. Clean off any material wrapped on feed chain sprockets

6.1.2 First 2000 bales, then thereafter every 10,000 bales or annually:

1. Grease dump shaft bearings with 2 pumps only.
2. Grease feed shaft bearings with 2 pumps only.
3. Grease wheel clutch hub.
4. Check wheel bearings.
5. Check setscrew torque on all sprockets.
6. Check setscrew torque on feed motor shaft coupling.
7. Check all mounting bolts.
8. Check chain tension of both feed and dump chains.

6.2 Adjustments

1. Feed and dump chains should be snug but not tight. Dump bar should turn by hand the entire 360 degrees of rotation with no more than 200 lbs effort.
2. Tie bar and push bar limit switches should be set to allow for proper travel of the arms on the extensions stroke and should flip the limit switch roller back just prior to reaching the retracting end of the cylinder stroke. The push bar is adjusted by moving the ½" square lugs forward or back to activate the switch at the proper time. The tie bar has no adjustments other than on the switch arm itself.
3. Stop unload limit switch should be set to stop the dump bar 12" or less from the rear of the machine and should not be held on by the dump bar once it is stopped. The incoming hay will normally push the bar back to the rear corner. If it goes on by the rear corner and starts uphill, refer to troubleshooting guide.
4. The pressure switch should be set to trip when box is full. If it is too low, it will dump with only a partial load of bales, if it is too high, it will not dump at all and the tractor hydraulics will stall out. Adjust by twisting the black ring located to the left of the electrical box behind the red and purple wire - clockwise to raise the setting.
5. The tie bar has its own speed control. Adjust the knob so the bar works at the desired speed. The control only affects the extension speed.

WARNING:

ALWAYS TURN POWER AND HYDRAULICS OFF BEFORE ATTEMPTING ANY SERVICE WORK.

7. TECHNICAL INFORMATION.

7.1 Machine Specifications.

Model:

Identification No:

Bale Capacity:

Capacity Bales/hour:

Tractor

Manufacturer:

Make-Model

Date:

Engine No.:

7.2 Setup Instructions

1. Bolt the right hand axle to frame with the (3) enclosed $\frac{1}{2}$ " x $3\frac{1}{2}$ " bolts. Bolt the bale guide triangle to the frame directly in front of the right hand wheel using the (2) enclosed $\frac{3}{8}$ " x 3" bolts. Install tire and wheel.
2. Install the baler hitch (purchased separately or built by the end user) onto the baler chute, referring to the attached drawing. Make sure the finished hitch height is 15" to 18".
3. Connect the accumulator to the baler and mount the supplied flow control valve, referring to attached drawing. Make sure the hydraulics are correctly connected based on open or closed center hydraulic systems. If you are unsure of what type your tractor is, contact your local tractor dealer. Install the hydraulic hoses, paying careful attention to the routing to keep them from getting damaged. Use the supplied hydraulic quick couplers to connect to the accumulator.
4. Route the supplied electrical cable along the hoses from the tractor, starting at the rear of the baler. Mount the control box in a convenient location near the operator and connect the 12VDC power using red for positive and black for negative or black for positive and white for negative depending on which connector you have
5. Connect the hoses to the tractor remotes, set any flow control devices on the tractor the full open, and set the lever on the supplied flow control to '3'. If there is an option on the tractor, select the hydraulics to "motor" operation to ensure a low resistance oil path back to the tractor reservoir.
6. Turn on the power on toggle switch at the control box and the power on toggle switch at the accumulator electrical box. With the power on, there should be a red indicator light lit up on the upper right hand corner of the hydraulic valve furthest to the right. Refer to the attached troubleshooting guide if that light is not lit.
7. Start the tractor and turn on the hydraulic flow. If flow is reversed, nothing will happen. To change the flow direction, either pull the hydraulic handle the opposite direction, or switch the hoses on the remotes. Once flow direction is established, the handle must be held in that position constantly to operate by either a detent, or tied back with a rubber cord.
8. Adjust the accumulator speed using the flow control, which was mounted on the baler tongue. The proper speed is about 3 on the dial depending on crop conditions. The feed paddles will pass about every 3 seconds at the correct speed.
9. Set bale length on baler so that one bale long is about the same dimension as two bales wide, (Model 950 only).

7.3 Installation Photos

Typical Baler Hitch Installation



Typical Flow Control Mounting

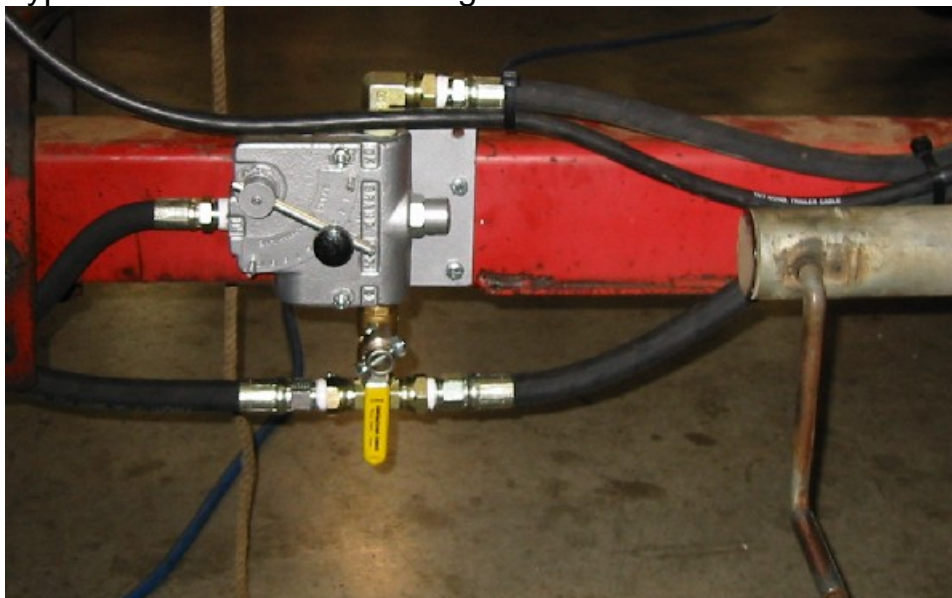

7.3.1 Hitch Installation Drawing

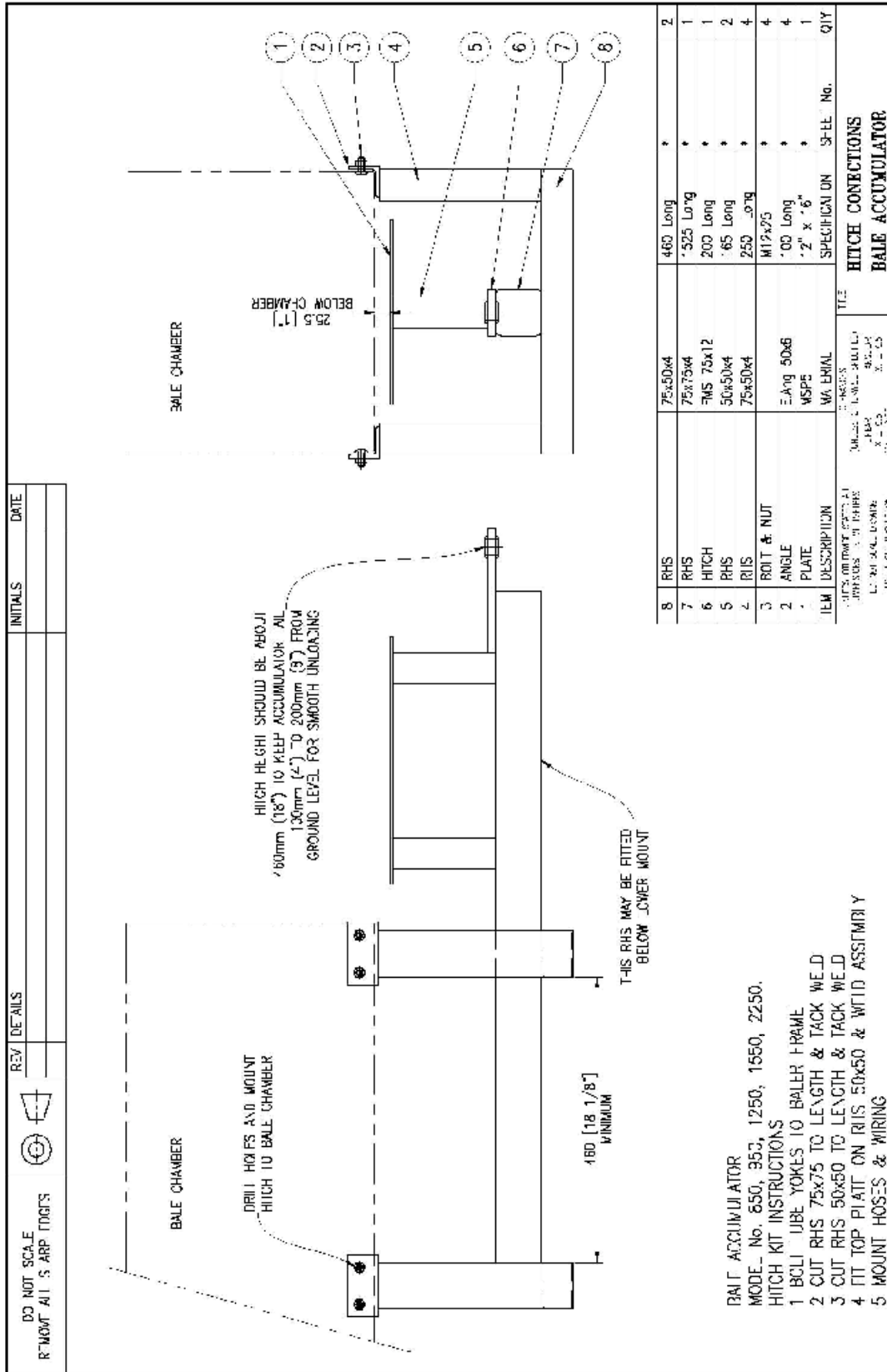

7.4 Hydraulic Circuit

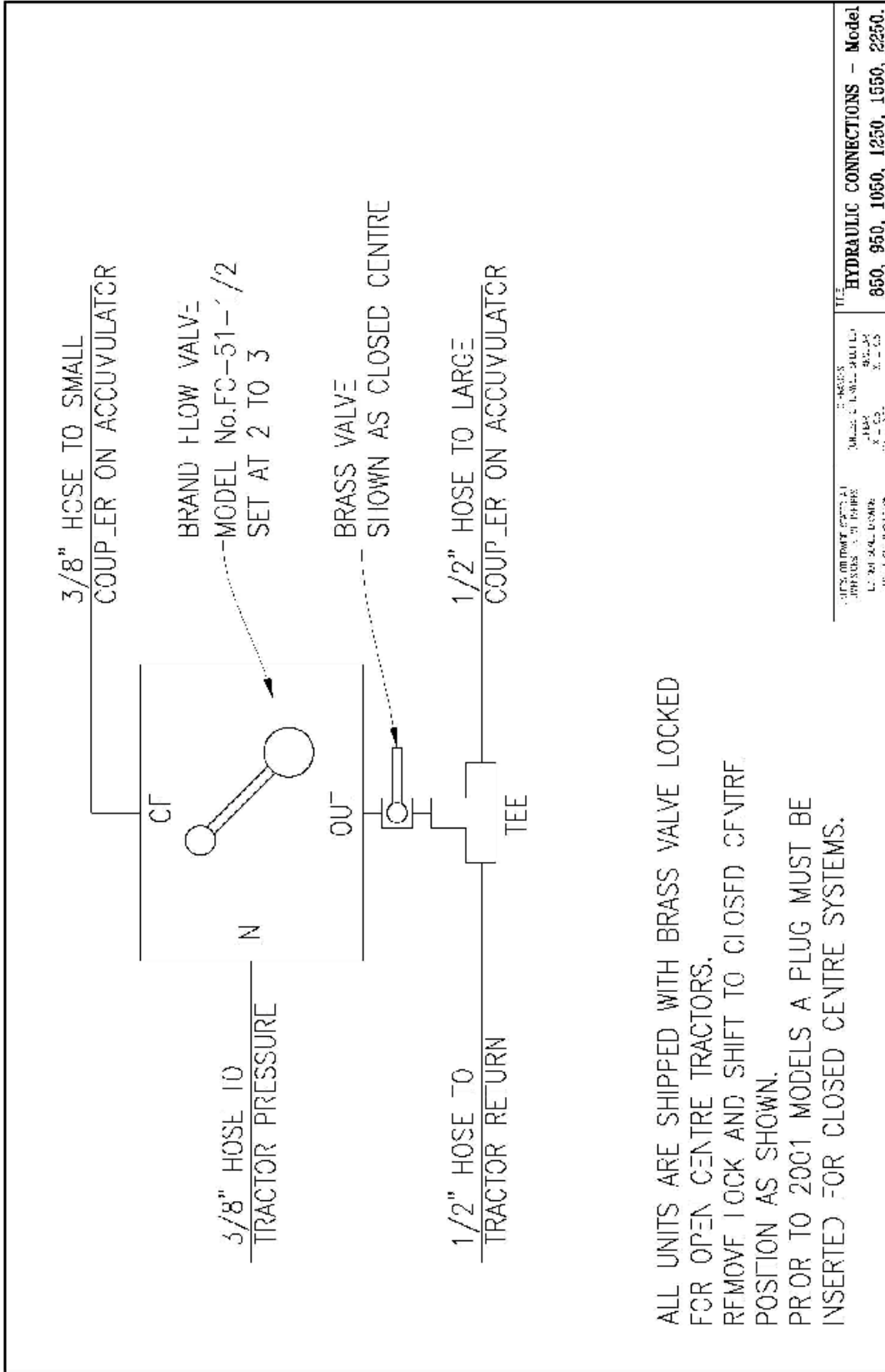

7.5 Wheel Clutch Assembly Drawing

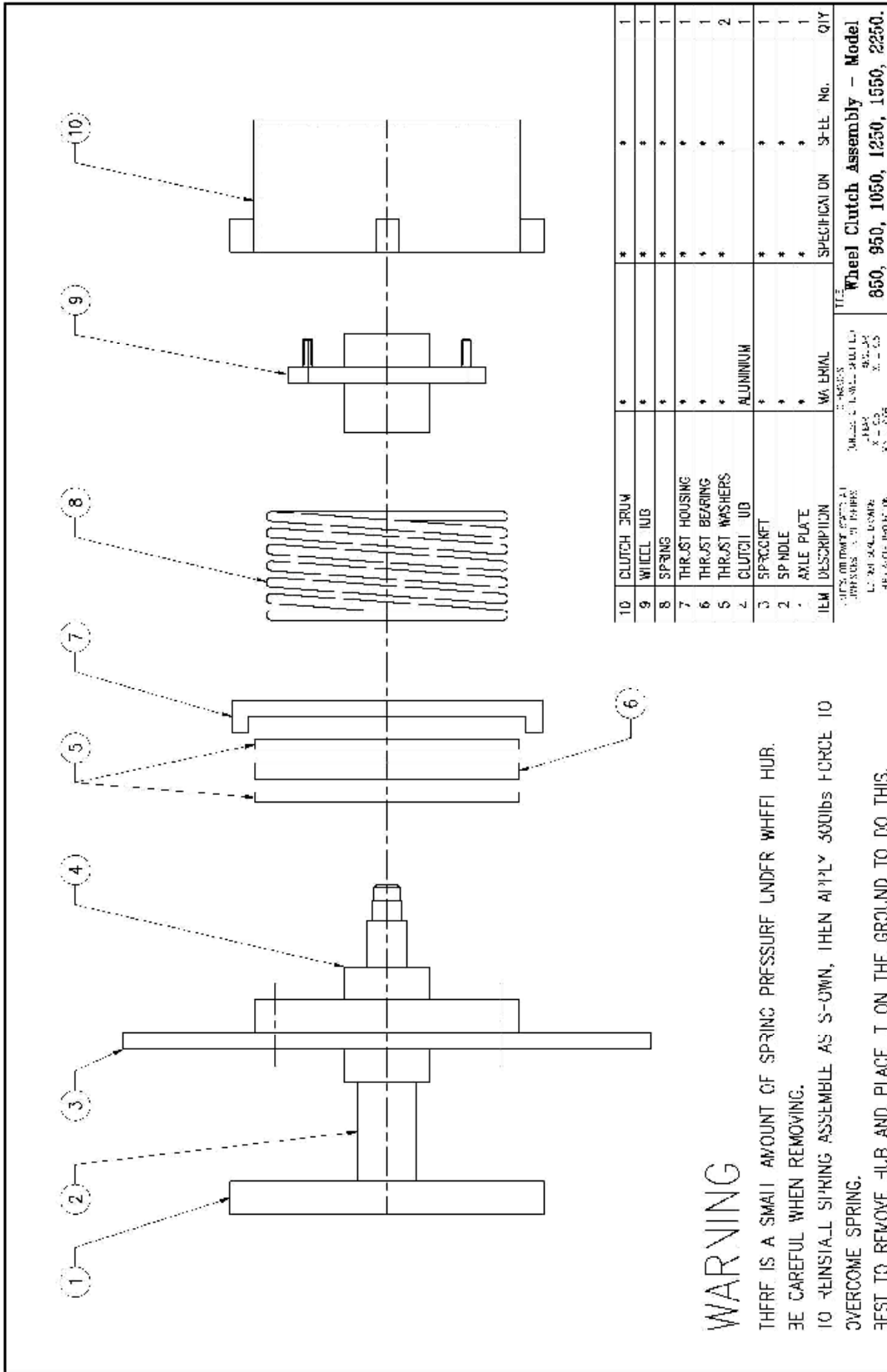

ITEM	DESCRIPTION	MATERIAL	SPECIFICATION	QTY
10	CLUTCH DRUM	*	*	1
9	WHEEL HUB	*	*	1
8	SPRING	*	*	1
7	THRUST HOUSING	*	*	1
6	THRUST BEARING	*	*	1
5	THRUST WASHERS	*	*	2
4	CLUTCH HUB	ALUMINIUM		1
3	SPROCKET	*	*	1
2	SPINDLE	*	*	1
1	AXLE PLATE	*	*	1

* SEE DRAWING FOR ALL DIMENSIONS
 * ALL DIMENSIONS IN INCHES
 * ALL DIMENSIONS IN MILLIMETERS
 * ALL DIMENSIONS IN METERS
 * ALL DIMENSIONS IN FEET

* SEE DRAWING FOR ALL DIMENSIONS
 * ALL DIMENSIONS IN INCHES
 * ALL DIMENSIONS IN MILLIMETERS
 * ALL DIMENSIONS IN METERS
 * ALL DIMENSIONS IN FEET

* SEE DRAWING FOR ALL DIMENSIONS
 * ALL DIMENSIONS IN INCHES
 * ALL DIMENSIONS IN MILLIMETERS
 * ALL DIMENSIONS IN METERS
 * ALL DIMENSIONS IN FEET

* SEE DRAWING FOR ALL DIMENSIONS
 * ALL DIMENSIONS IN INCHES
 * ALL DIMENSIONS IN MILLIMETERS
 * ALL DIMENSIONS IN METERS
 * ALL DIMENSIONS IN FEET

* SEE DRAWING FOR ALL DIMENSIONS
 * ALL DIMENSIONS IN INCHES
 * ALL DIMENSIONS IN MILLIMETERS
 * ALL DIMENSIONS IN METERS
 * ALL DIMENSIONS IN FEET

* SEE DRAWING FOR ALL DIMENSIONS
 * ALL DIMENSIONS IN INCHES
 * ALL DIMENSIONS IN MILLIMETERS
 * ALL DIMENSIONS IN METERS
 * ALL DIMENSIONS IN FEET

* SEE DRAWING FOR ALL DIMENSIONS
 * ALL DIMENSIONS IN INCHES
 * ALL DIMENSIONS IN MILLIMETERS
 * ALL DIMENSIONS IN METERS
 * ALL DIMENSIONS IN FEET

* SEE DRAWING FOR ALL DIMENSIONS
 * ALL DIMENSIONS IN INCHES
 * ALL DIMENSIONS IN MILLIMETERS
 * ALL DIMENSIONS IN METERS
 * ALL DIMENSIONS IN FEET

* SEE DRAWING FOR ALL DIMENSIONS
 * ALL DIMENSIONS IN INCHES
 * ALL DIMENSIONS IN MILLIMETERS
 * ALL DIMENSIONS IN METERS
 * ALL DIMENSIONS IN FEET

* SEE DRAWING FOR ALL DIMENSIONS
 * ALL DIMENSIONS IN INCHES
 * ALL DIMENSIONS IN MILLIMETERS
 * ALL DIMENSIONS IN METERS
 * ALL DIMENSIONS IN FEET

* SEE DRAWING FOR ALL DIMENSIONS
 * ALL DIMENSIONS IN INCHES
 * ALL DIMENSIONS IN MILLIMETERS
 * ALL DIMENSIONS IN METERS
 * ALL DIMENSIONS IN FEET

* SEE DRAWING FOR ALL DIMENSIONS
 * ALL DIMENSIONS IN INCHES
 * ALL DIMENSIONS IN MILLIMETERS
 * ALL DIMENSIONS IN METERS
 * ALL DIMENSIONS IN FEET

* SEE DRAWING FOR ALL DIMENSIONS
 * ALL DIMENSIONS IN INCHES
 * ALL DIMENSIONS IN MILLIMETERS
 * ALL DIMENSIONS IN METERS
 * ALL DIMENSIONS IN FEET

WARNING

THERE IS A SMALL AMOUNT OF SPRING PRESSURE UNDER WHEEL HUB. BE CAREFUL WHEN REMOVING. TO REINSTALL SPRING ASSEMBLY AS SHOWN, THEN APPLY SQUIDS FORCE TO OVERCOME SPRING. BEST TO REMOVE HUB AND PLACE IT ON THE GROUND TO DO THIS.

7.6.2 Model 950

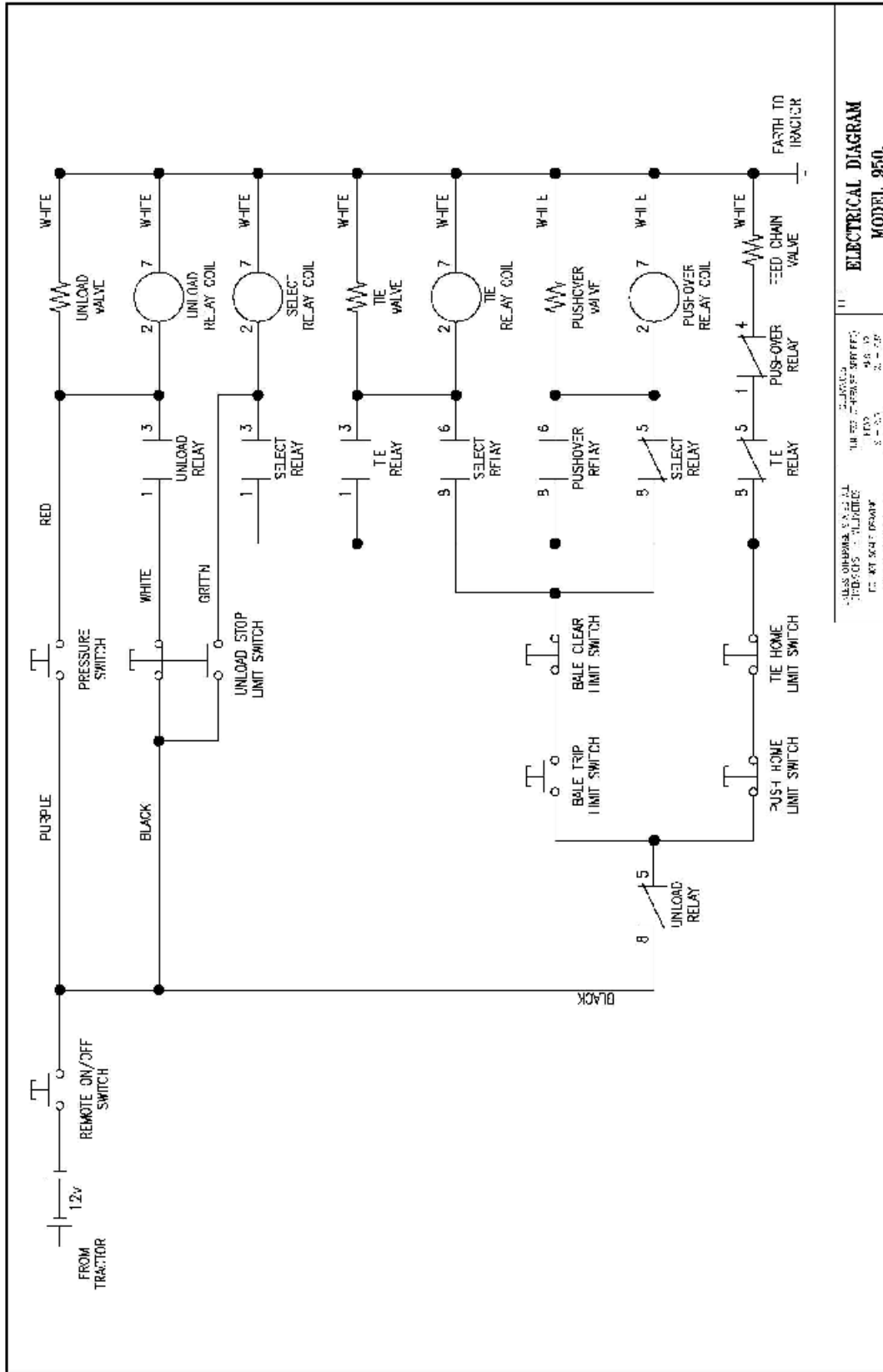

7.7 Parts List

BALE ACCUMULATOR PARTS LIST

Model 850/950/1050/1250/1550/2250

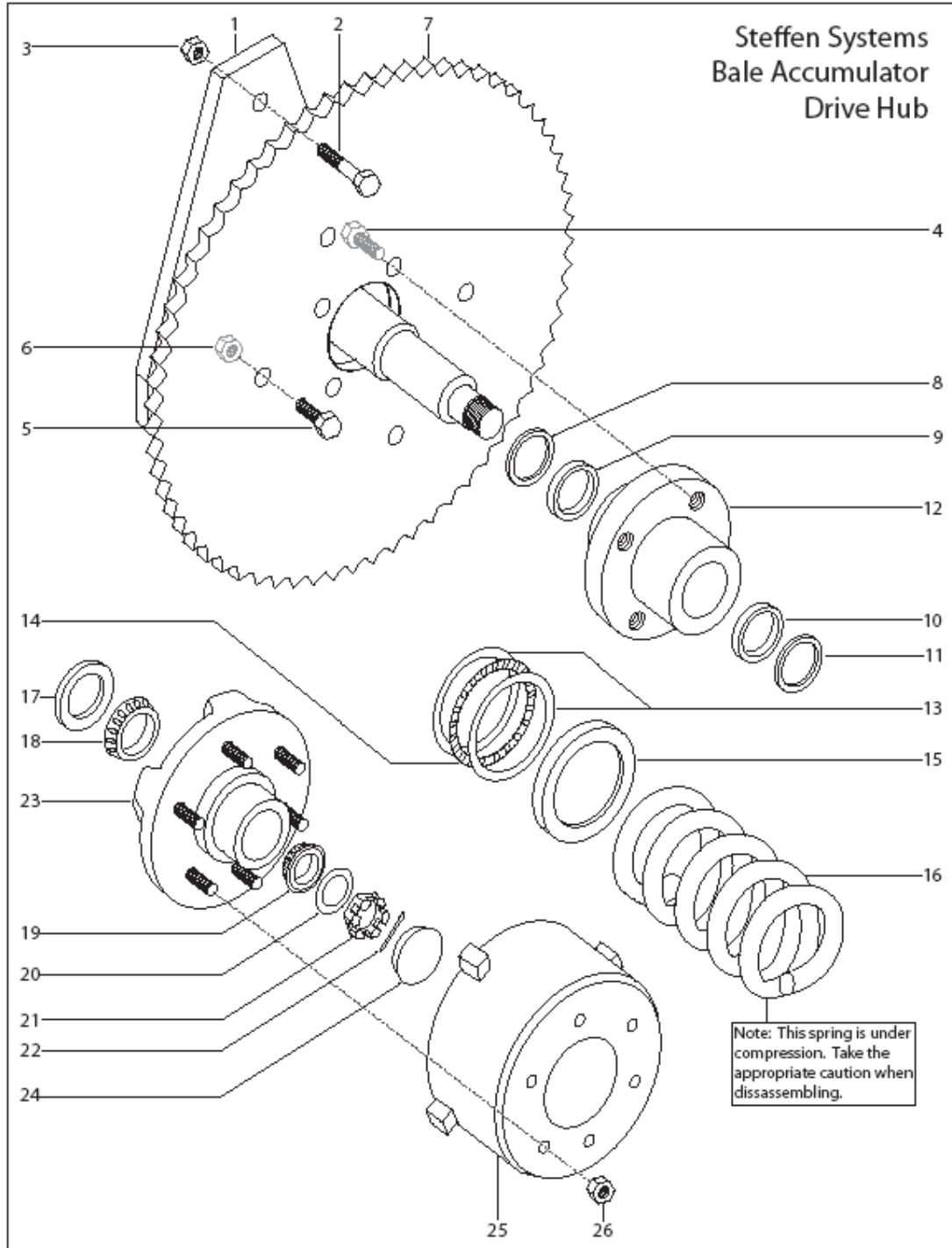

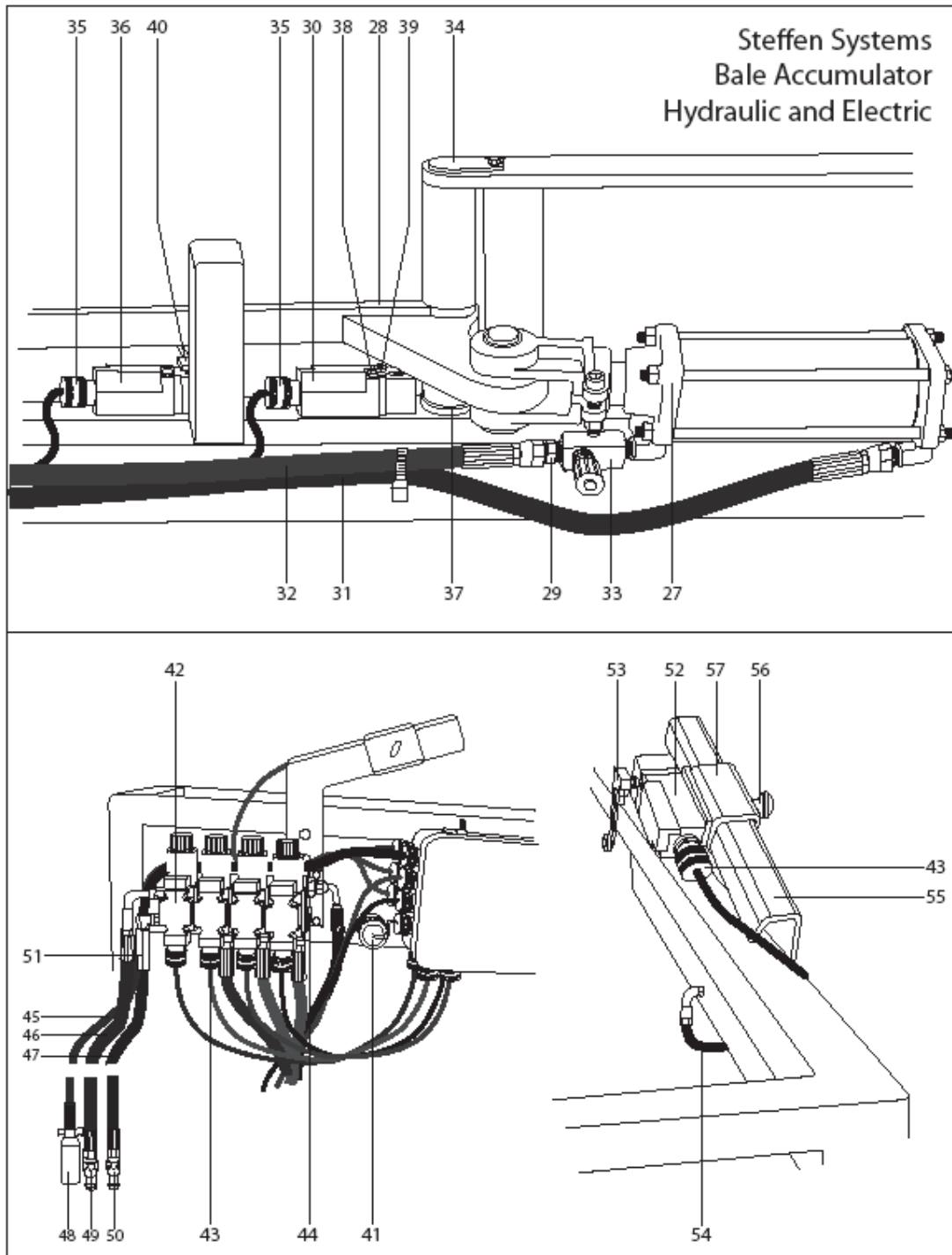

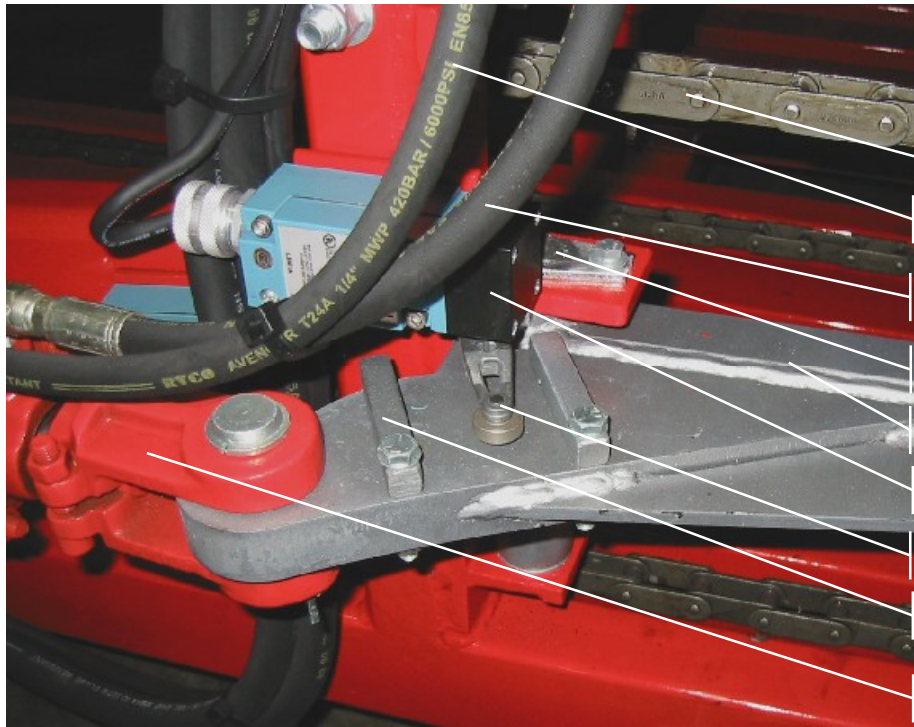

- 60
- 61
- 62
- 63
- 64
- 65
- 66
- 67
- 68

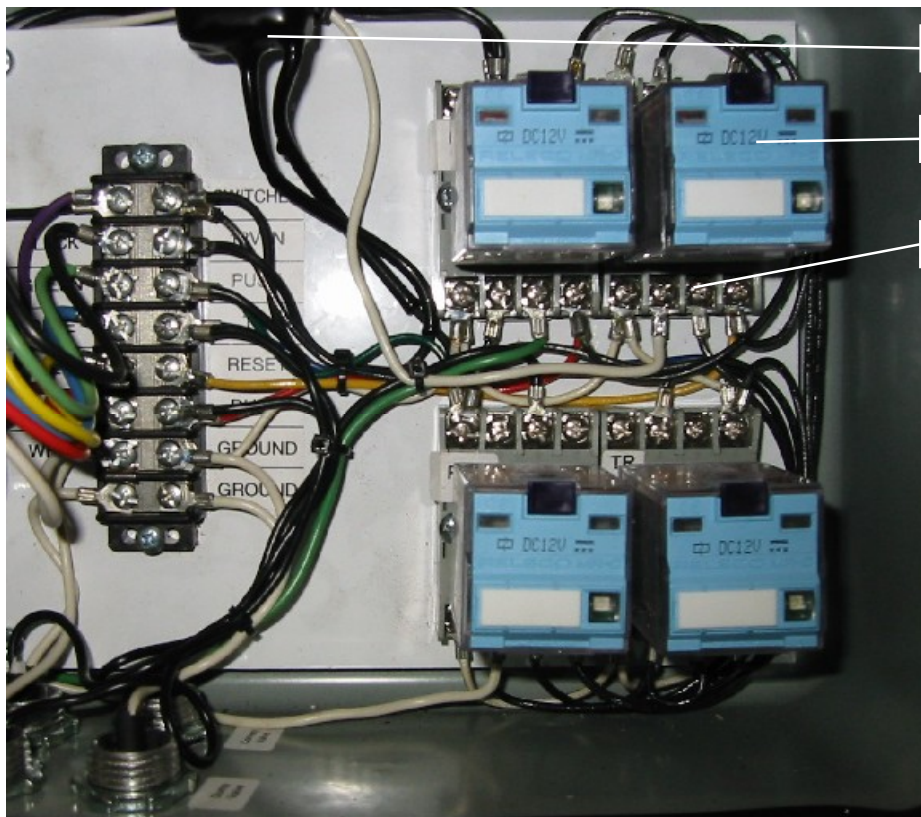

- 69
- 70
- 71

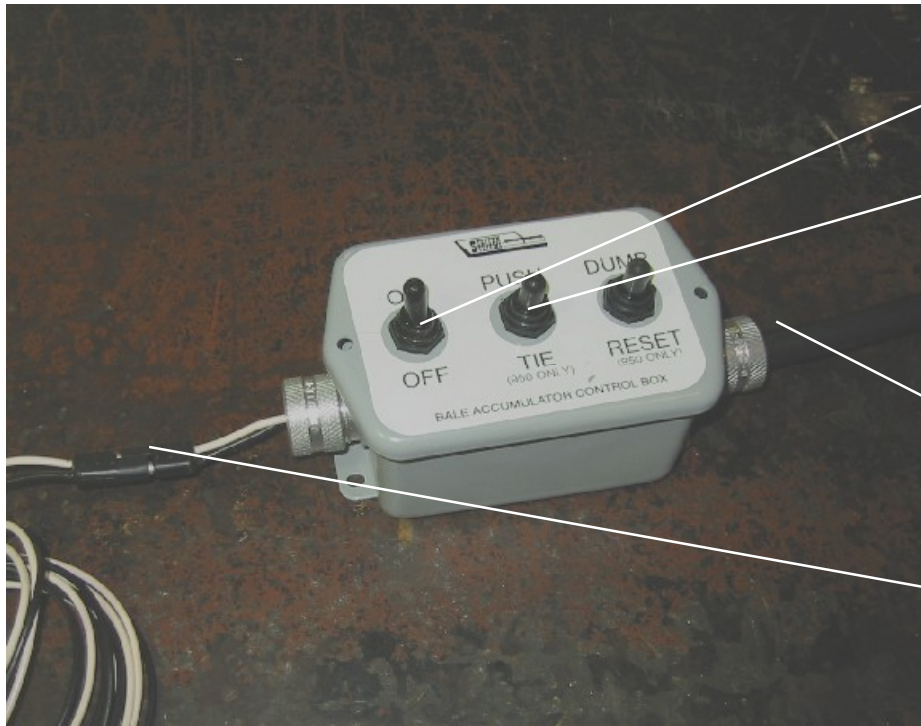

72

73

74

75



76

77

78

79

80

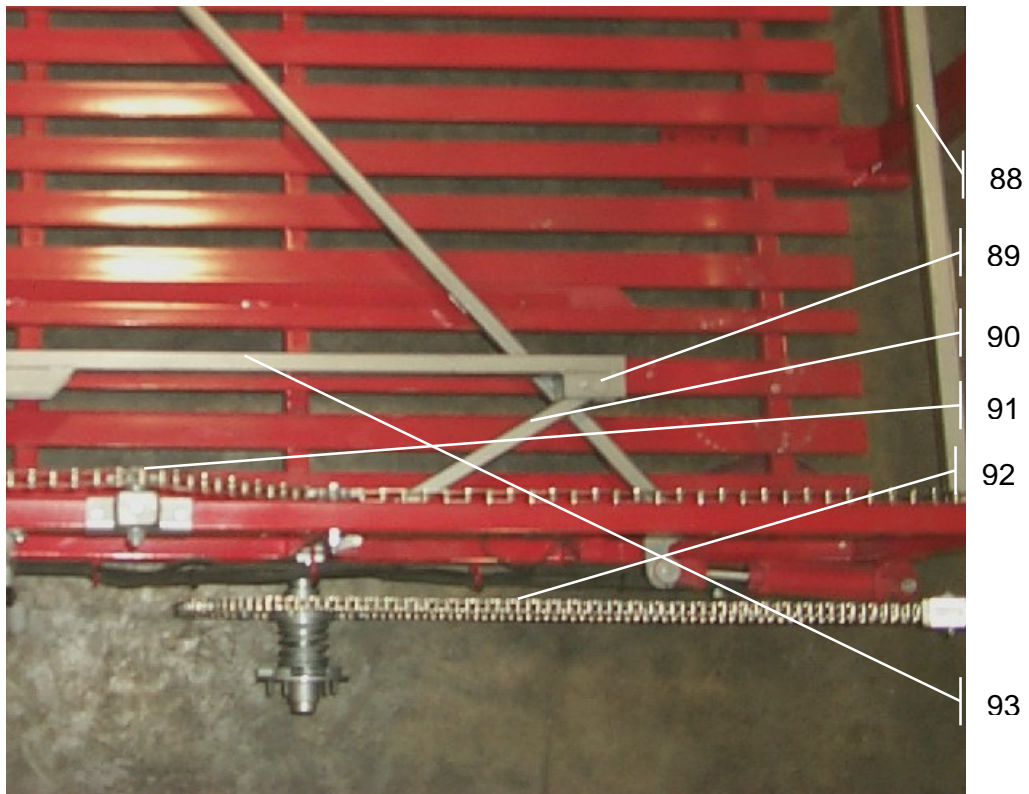
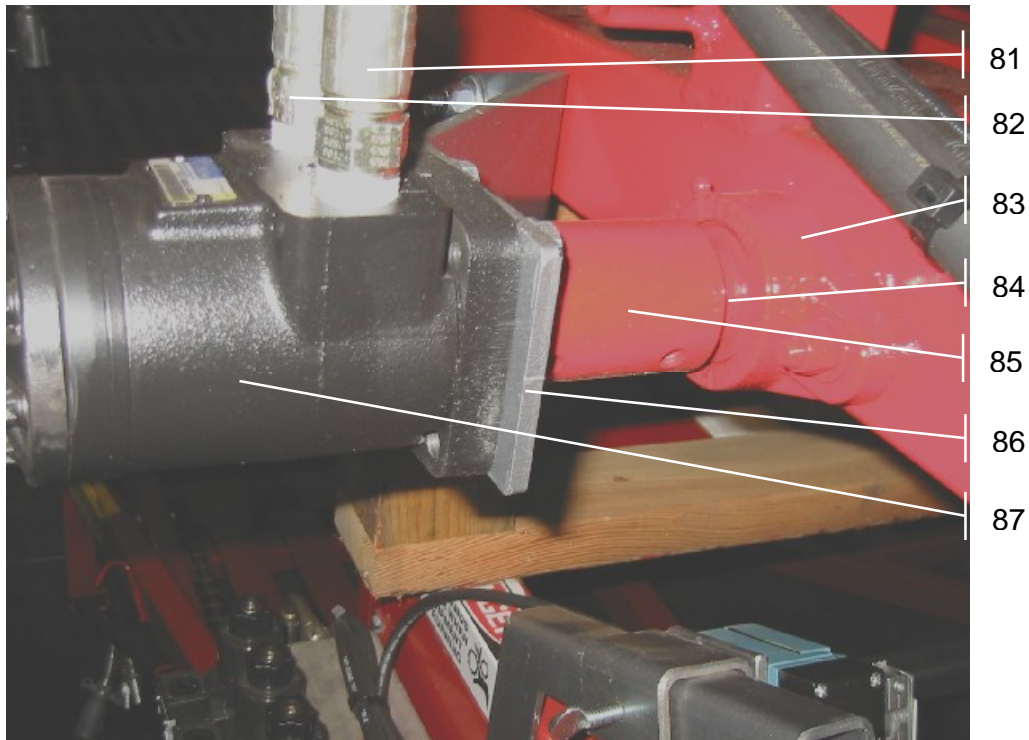

Item No	Part No	Description
1-24	S9500	Wheel clutch assembly
8-11	S9501	Wheel clutch seal kit
17-19	S9502	Wheel bearing set
15	S9503	Thrust bearing housing
13-14	S9504	Clutch spring thrust bearing and washer
12	S9505	Aluminum clutch piston
1	S9506	Axle with mount plate drive side
7	S9507	Drive sprocket 84 tooth
23	S9508	Wheel hub 6 on 6.5 bolt pattern (5x5.5 bolt pattern, 1973-2003)
25	S9509	Drive hub with lugs 8"
	S9510	Tire and wheel assembly
2		1/2x3-1/2 bolt
3		1/2 nylon insert nut
4		1/2x1 bolt
5		1/2x1 socket head cap screw
6		1/2 nylon insert jam nut
20		Axle washer
21		Axle nut
22		Cotter key
24		Dust cover
26		Lug nut
16	S9511	Clutch return spring
92c	S9512	Plastic drive chain tensioner
92	S9513	Drive chain #60
92a	S9514	Drive chain master link #60
92b	S9515	Drive chain offset half link #60
44	S9516	Hydraulic manifold 4 station, only Model 950
44a	S9517	Hydraulic manifold 3 station, all other models
42	S9518	Nachi single solenoid valve
41	S9519	Pressure switch – Barksdale
87	S9520	Feed chain hydraulic motor
33	S9521	Tie bar cylinder flow control with adaptors
27, 68	S9522	2"x6" cylinder push or tie, all Models except 2250
27a	S9523	2"x8" cylinder push only Model 2250
29		1/4" male pipe x #6 male JIC adapter
	S9524	Brand FC-51-1/2 flow control
50	S9525	3/8" male quick connector, pressure hose
	S9526	3/8" female quick connector, pressure hose
49	S9527	1/2" male quick connector, return hose
	S9528	1/2" female quick connector, return hose
47	S9529	3/8" pressure hose to baler
46	S9530	1/2" return hose to baler
81	S9531	3/8" feed motor pressure hose
82	S9532	3/8" feed motor return hose
61	S9533	1/4" push bar extend hose
62	S9534	1/4" push bar retract hose
	S9535	1/4" dump clutch hose
31	S9536	1/4" tie bar extend hose
32	S9537	1/4" tie bar return hose
54	S9538	1/4" pressure switch hose
72-75	S9539	Cab control box with 27 foot cord
69, 72	S9540	2 position toggle switch with boot
73	S9541	3 position toggle switch with boot
	S9542	Circuit breaker
	S9543	Control box face plate
74	S9544	7-wire control cable only, tractor end 27 foot long

45	S9545	7-wire control cable only, accumulator end 12 foot long
48	S9546	7-wire male connector
74a	S9547	7-wire female connector with boot
35, 43	S9548	Aluminum cord connector
70	S9549	Relay 12 VDC
71	S9550	Relay base
36, 52	S9551	Dump. Trip or Clear switch LSA1A
30, 65	S9552	Tie or Push switch LSN1A
80	S9553	Loop arm for Clear switch LSZ-61
40	S9554	Straight black rod for Trip switch LSZ-68
39, 66	S9555	Solid roller arm for Tie or Push switch LSZ-51B
53	S9556	Adjustable arm for Dump Stop switch LSZ-52D
38		10-32x1-3/4 socket head capscrew
67	S9557	Pushbar switch lug
85	S9558	Feed chain shaft coupler 1" solid
77b	S9560	Dump or Feed chain cross bolt 5/8x4-1/2
	S9561	Dump chain adjuster bolt 6" long
60, 91	S9562	Dump chain 10 foot section (4 per unit)
	S9563	Dump chain master link C2060H
	S9564	Dump chain offset half link C2060H
	S9565	Dump chain side bar link with 5/16" holes
	S9566	Dump shaft bearing
	S9567	Dump shaft main sprocket 19 tooth
	S9568	Dump shaft drive sprocket 13 tooth
	S9569	Dump drive shaft Model 850, 950, 1250
	S9570	Dump drive shaft Model 1050, 1550, 2250
88	S9571	Dump bar. Model 850, 950, 1250
	S9572	Dump bar. Model 1050, 1550, 2250
77a	S9573	Feed chain adjuster bolt 10" long
79	S9574	Feed chain section (6 per unit)
79a	S9575	Feed chain master link C2060H
79a	S9576	Feed chain offset half link C2060H
78	S9577	Feed chain paddle mounting link C2060H A-1 with 5/16" hole
83	S9578	Feed shaft bearing 1"
83a	S9579	Feed shaft main sprockets 15 tooth
84	S9580	Feed shaft. specify model
76	S9581	Feed paddle. all models except 2250
	S9582	Feed paddle. Model 2250
77, 91	S9583	? " bore idler sprocket. 15 tooth
	S9584	1/2" bore idler sprocket. 15 tooth
63	S9585	Push bar long pivot pin
89	S9586	Push bar short pivot pin
63b	S9587	Push bar pivot bushing 1x3/4
34	S9588	Tie bar pivot pin
37	S9589	Tie bar pivot bushing 1-1/4x1
	S9591	Bungie cord assembly for throat
64	S9592	Push bar front link with cylinder ear
90	S9593	Push bar rear link
28	S9594	Tie bar complete
93	S9595	Push bar complete, Model 950
	S9596	Push bar complete, all other models, specify
86	S9597	Feed chain motor mounting bracket
	S9598	Hydraulic mounting adaptor for pressure switch
55		Dump stop switch mount
56		3/8x1 thumbscrew
57		Dump stop switch slider mount
51	S9599	Check valve with adaptor for pressure line

7.8 Fault Finding

7.8.1 Feed chain does not rotate

1. Push bar home limit and tie bar home limit must both be retracted
2. Dump stop switch must be off of the dump bar
3. Hydraulic flow is not coming out of the tractor, check all connections are fully plugged in and the handle is pulled in the proper direction
4. Electrical is not connected, if condition #1 is correct, then there should be a red triangle shaped light lit up in the hydraulic valve furthest to the right . There must be a minimum of 11 volts present between the white wire at the bottom and the purple wire at the top of the terminal strip
5. Check for mechanical binding. The chain may have jumped a tooth, or there may be foreign material wrapped on the shaft preventing movement

7.8.2 Push bar or tie bar does not activate properly

1. Check voltage as in 7.8.1.4, you need a minimum of 11 volts DC for proper operation.
2. Hydraulic flow is not coming out of tractor, check hydraulics as in 7.8.1.3
3. Bale clear limit switch loop is stuck in the 'on' position, check that it operates freely and clicks when activated.
4. Bale trip limit straight black rod switch is not operating properly, check that it clicks when activated manually.
5. A relay may be defective on that function, replace with a new one or switch it with another in the box.
6. Check that the unload stop switch is released and that the dump bar is not stuck on it.
7. The blue or green wire is shorted in the cable to the tractor. Remove the blue and the green wire from the terminal strip at the accumulator box. This will not affect the automatic operation, just the manual override

7.8.3 Tie bar does not activate after dumping

1. Adjust the dump stop switch slider to closer to the tractor. If the black rod trip switch is held on after the dump stop switch is activated, the tie bar will activate with no bales, resulting in a skipped tie bale
2. Trip switch is too long (should be about 5") or bent rearwards, hanging up on the hay of frame
3. Check the dump stop switch to be sure the dump bar is contacting it as it passes
4. Check for low voltage, as is 7.8.1.4
5. Adjust dump chains tighter as the dump stop switch is not being triggered long enough to activate tie sequence

WARNING:

ALWAYS TURN POWER AND HYDRAULICS OFF BEFORE ATTEMPTING ANY SERVICE WORK

7.8.4 Tie bales catch far side of accumulator

1. Bales are too long, shorten bales to proper length of 36-38"
2. Spear tabs are broken off of tie bar tip allowing bales to slide
3. Tie bar is too fast, slow down by turning the flow control on the tie bar cylinder clockwise.
4. Dump chain is too tight or bound up, check that it moves freely with no more than 200 lbs of pull

7.8.5 Accumulator tries to dump with partial package

1. The pressure switch setting is too low, adjust it higher by turning the black knurled ring clockwise about 2 turns at a time
2. The push bar is extending past its limit switch, adjust the switch arm lug to the proper position. The switch arm should flip over when the arm is about 3" from the end of its stroke. Too short will allow bales to block the throat, too long will cause the dump to engage prematurely
3. Check for a short in the red wire to the tractor. This wire may be disconnected at the terminal strip without affecting the automatic operation of the machine. This will just remove the manual override from being a potential problem.

7.8.6 Accumulator does not dump

1. Pressure switch setting is too high, adjust down by turning black ring behind the red and purple wire counter clockwise about 2 turns at a time.
2. Pressure switch is faulty or plugged with debris, replace with a new one. This can be tested by connecting a jumper wire between the purple and the red wire with the toggle switch on and hydraulic power off. When connected, the top left relay will light up indicating the remainder of the system is functioning correctly
3. Dump chain is bound up, resulting in the tire sliding rather than turning chain. Check for proper drag on dump chain by rotating the dump chain by hand the full 360 degrees of rotation with less than 200 lbs. of pull
4. Hay is too wet or heavy, creating more friction on the deck that the tire has traction for unloading.
5. Check for a short in the red wire to the tractor. This wire may be disconnected at the terminal strip without affecting the automatic operation of the machine. This will just remove the manual override from being a potential problem.

7.8.7 Dump chain doesn't stop after unloading

1. Stop unload limit switch is being missed, tighten dump chain or adjust length of stop unload switch to contact dump bar longer
2. Return hose to tractor is restricted or has come unplugged. Check that tractor flow controls are fully open, plumbing is correct on the Brand flow control, and that all hydraulic hose connections are secure.
3. In some cases, the wheel bearings in the drive axle may be loose, resulting in a mechanical binding of the wheel

WARNING:

ALWAYS TURN POWER AND HYDRAULICS OFF BEFORE ATTEMPTING ANY SERVICE WORK

7.8.8 Bales fall out of the rear of the machine

1. All of the conditions in 7.8.7 will also affect this.
2. Adjust unload stop switch so the dump bar stops between 12-24" from the tail of the machine. The incoming bales will move the dump bar to the rear as they come in. Be sure that the dump bar does not stop on the dump stop switch, but travels past it.
3. Wheel bearings are loose, binding the hub so it can't quickly release. Adjust wheel bearings.
4. Tighten dump chain to keep it from travelling too far by inertia
5. Tie arm is too fast, throwing the bar past, slow by the same as 7.8.4
6. As a last resort, you can remove one of the spacer washers at the lower rear idler sprocket. This creates a pinch point as the dump bar reaches the corner, causing it to stop.

7.8.9 Everything is stalled

1. Unload stop limit switch is stuck on, rotate dump bar by hand to move it off of the dump stop switch.
2. Electric power from tractor is disconnected. Check that red triangle light is lit on the feed chain valve when the push and tie bars are in the retracted positions.
3. Hydraulic flow is disconnected, check hose connections.
4. Check that all relays are properly plugged in

7.8.10 Wheel clutch, tie bar or push bar extends by itself and locks

1. Hydraulic return hose is unplugged or restricted.
2. Unload stop switch is stuck on, move dump bar off switch.
3. On units prior to 2001, the hoses can be reversed. Switch hoses.
4. Hydraulic handle in tractor is not completely activated, tie into position

7.8.11 Wheel clutch, tie bar or push bar "floats" out of position

1. Backpressure in hydraulic return line is too high, check for blockage. Occasionally on older tractors, try switching lines on the tractor remotes or change remotes as one may be more restrictive.
2. Return line must be 1/2" hose and routed to the least restrictive method of connection to the oil reservoir.
3. Hydraulics are running too fast, slow down flow control to 3 to 3-1/2.
4. Feed chain is too loose, not creating enough drag for cylinders to retract, tighten feed chain
5. Hydraulic quick couplers may be faulty, check connections.

WARNING: ALWAYS TURN POWER AND HYDRAULICS OFF BEFORE ATTEMPTING ANY SERVICE WORK

7.8.12 Bales get cut in half by push bar

1. Bale clear switch is broken or bent down, allowing push bar to activate prematurely. Fix loop or switch.
2. Bale length is too long, forcing bales into the accumulator.
3. Field conditions are rough, allowing bales to jump in the air and miss the limit switch

7.8.13 Bales get caught in throat when turning

1. Rubber cords are missing on throat of accumulator.
2. Bales are overly misshapen.

7.8.14 Bales slide around in accumulator

1. If you are on steep terrain, the bales may slide around. To fix this, tie twine or wire around the center frame tubing just behind the feed chain so the bales cannot slide back as easily. Optionally, you can apply some 3M self adhesive sand paper to the tops of the tubes. This is available through your local auto parts.
2. Ground conditions are too rough, slow down travel speed.

7.8.15 Tie bales roll on their sides when dumped

1. Check hitch elevation. The top of the rear tubes in the accumulator should be no more than 6 inches from the ground.
2. Ground is very uneven and it is impossible for bales to stay flat as they are dumped.

7.8.16 Tie bar extends and stays

1. Tie bar limit switch is damaged or out of adjustment. Readjust or replace.
2. The dump stop switch is staying on after dumping. Make sure the dump bar travels off the switch after dumping, this will automatically happen if there are bales in the machine

7.8.17 All functions move but have no power

1. If the feed chain is attempting to move while other functions are happening, there is dirt trapped in the feed valve, jamming the movement. This condition is present if the light is off on the feed valve, but the chain is moving. Replace valve or clean.

WARNING: ALWAYS TURN POWER AND HYDRAULICS OFF BEFORE ATTEMPTING ANY SERVICE WORK

7.8.18 Other helpful items to check

1. Check that all electrical wires are tied up and not in a position to get pinched or cut off, by the turning of the machine, or in the area by the push bar cylinder
2. Make sure hoses are routed in a manner that they cannot get pinched or kinked.
3. The shape of the bales can make a big difference in the consistency of the machine. It is important to keep control of weights and lengths and shape of the bales.
4. Voltage drops can be a problem with diesel powered tractors as they do not require a constant 12 volts to operate like a gasoline engine. If the voltage drops below 11 volts at the accumulator, a variety of problems can occur.
5. Excessive field speeds may cause erratic functioning of the machine. Slow travel speed to the appropriate speed for the field conditions

WARNING: ALWAYS TURN POWER AND HYDRAULICS OFF BEFORE ATTEMPTING ANY SERVICE WORK

8. PLANT SAFETY ASSESSMENT & EVALUATION

8.1 Hazard Identification Checklist

HAZARD	YES /NO	DESCRIPTION
A. ENTANGLEMENT		
1. Can anyone's hair, clothing, gloves, necktie, jewelry, cleaning brushes, rags or other materials become entangled with moving parts of the machine, or materials in motion?	Yes	There are many moving parts ie. chains, sprockets & other pinch points on the machine.
B. CRUSHING		
1. Can anyone be crushed due to:		
a. material falling off the machine?	No	
b. uncontrolled or unexpected movement of the machine or its load?	Yes	The machine is fully automatic, sensors can activate at any time.
c. lack of capacity for the machine to be slowed, stopped or immobilized?	Yes	If the machine is incorrectly attached to the baler or tractor.
d. the machine tipping or rolling over?	No	
e. parts of the machine collapsing?	No	
f. coming in contact with moving parts of the machine during testing, inspection, operation, maintenance, cleaning or repair?	Yes	The machine is fully automatic sensors can be activated at any time & chains can engage at any time.
g. being thrown off or under the machine?	No	
h. being trapped between the machine and materials or fixed structures?	Yes	If vision is blocked for the operator of the machine.
i. other factors not mentioned		
C. CUTTING, STABBING & PUNCTURING		
1. Can anyone be cut, stabbed or punctured due to:		
a. coming in contact with sharp or flying objects?	Yes	The machine is fully automatic, sensors can activate at any time.
b. coming in contact with moving parts of the machine during testing, inspection, operation, maintenance, cleaning or repair of the plant?	Yes	The machine is fully automatic sensors can be activated at anytime & chains can engage at any time.
c. the machine, parts of the machine or work pieces disintegrating?	Yes	Due to lack of maintenance or regular checks.
d. work pieces being ejected?	No	
e. mobility of the machine?	Yes	If vision is blocked for the operator of the machine.
f. uncontrolled or unexpected movement of the machine?	Yes	The machine is fully automatic sensors can be activated at any time & chains can engage at any time.
g. other factors not mentioned?		

D. SHEARING		
1. Can anyone's body parts be sheared between two parts of the machine, or between a part of the machine and a work piece or structure?	Yes	The machine is a hydraulic powered machine. The two main features ie. The push arm & the tie arm are exposed when in operation.
E. FRICTION		
1. Can anyone be burnt due to contact with moving parts or surfaces of the machine?	No	
F. STRIKING		
1. Can anyone be struck by moving objects due to:		
a. uncontrolled or unexpected movement of the machine or material handled by the plant?	No	
b. the machine, parts of the machine or work pieces disintegrating?	No	
c. work pieces being ejected?	Yes	As the machine ejects its load.
d. mobility of the machine?	No	
e. other factors not mentioned?	No	
G. HIGH PRESSURE FLUIDS		
1. Can anyone come in contact with fluids under pressure, due to plant failure or misuse of the machine?	Yes	Hydraulic hoses may wear or become loose.
H. ELECTRICAL		
1. Can anyone be injured by electrical shock or burnt due to:		
a. the machine contacting live electrical conductors?	No	
b. the machine working in close proximity to electrical conductors?	No	
c. overload of electrical circuits?	No	
d. damaged or poorly maintained electrical leads and cables?	No	
e. damaged electrical switches	No	
f. water near electrical equipment?	No	
g. lack of isolation procedures?	No	
h. other factors not mentioned?	No	
I. EXPLOSION		
1. Can anyone be injured by an explosion of gases, vapours, liquids, dusts or other substances, triggered by the operation of the plant or by material handled by the machine?	No	

J. SLIPPING, TRIPPING OR FALLING		
1. Can anyone using the machine, or in the vicinity of the machine, slip, trip or fall due to:		
a. uneven or slippery work surfaces?	Yes	In a field situation the ground may be uneven or slippery.
b. poor housekeeping, eg. garbage in the vicinity of the machine, spillage not cleaned up?	No	
c. obstacles being placed in the vicinity of the machine?	No	
d. other factors not mentioned?	No	
2. Can anybody fall from a height due to:		
a. lack of proper work platform?	No	
b. lack of proper stairs or ladder?	No	
c. lack of guardrails or other suitable protection	No	
d. unprotected holes, penetrations or gaps?	No	
e. poor floor or walking surfaces such as the lack of a slip resistant surface?	No	
f. steep walking surfaces?	No	
g. collapse of the supporting surfaces?	No	
h. other factors not mentioned?	No	
K. ERGONOMICS		
1. Can anyone be injured due to:		
a. poorly designed seating?	No	
b. repetitive body movement?	No	
c. constrained body posture or the need for excessive effort?	No	
d. design deficiency causing mental or psychological stress?	No	
e. inadequate or poorly placed lighting?	No	
f. lack of consideration given to human traits and natural limitations?	No	
g. other factors not mentioned?	No	
L. SUFFOCATION		
1. Can anyone be suffocated due to lack of oxygen, or atmospheric contamination?	No	
M. HIGH TEMPERATURE OR FIRE		
1. can anyone come into contact with objects at high temperature?	No	
2. can anyone be injured by fire?	No	

N. TEMPERATURE (thermal comfort)		
1. can anyone be injured or suffer ill-health due to exposure to high or low temperature?	No	
O. OTHER HAZARDS		
1. Can anyone be injured or suffer ill-health from exposure to:		
a. chemicals?	No	
b. toxic gases or vapours?	No	
c. fumes?	No	
d. dust?	No	
e. noise?	No	
f. vibration?	No	
g. radiation?	No	
h. other factors not mentioned?	No	

8.2 Risk Assessment Table

CONSEQUENCE	PROBABILITY			
	frequent	probable	occasional	remote
catastrophic	HIGH	HIGH	HIGH	HIGH
fatal	HIGH	HIGH	HIGH	MEDIUM
critical	HIGH	HIGH	MEDIUM	LOW
marginal	HIGH	MEDIUM	LOW	LOW
negligible	MEDIUM	LOW	LOW	LOW

8.3 Hazard Identification and Control

HAZARD	RISK ASSESSMENT	RISK CONTROL SHORT TERM	RISK CONTROL LONG TERM
A-1	Low	Read and understand the operator's manual	Permanent safety guards fitted and safety signs in place
B-1B	Low	Operator to isolate machine & apply handbrake before attempting any service or maintenance work	Read and understand the operators manual.
B-1C	Low	Correct coupling when attaching the machine to the baler.	Use only the correct hitch mount. And install correctly refer Operators manual.
B-1F	Low	All power to the machine must be off and oil supply stopped	Read and understand operators manual. Permanent safety guards fitted and safety signs in

		before any maintenance to be carried out.	place.
B-1H	Low	Only a trained operator to operate the machine.	Read and understand operators manual. No personnel near plant when operating.
C-1A	Low	Read and understand operators manual.	Permanent safety guards and safety signs in place.
C-1B	Low	Read and understand operators manual.	Regular maintenance & daily checks to be carried out.
C-1C	Low	Regular daily checks and maintenance	Read and understand operators manual.
C-1E	Low	Only a trained operator to operate the machine.	Read and understand operators manual. No personnel near machine when operating.
C-1F	Low	Only a trained operator to operate the machine	Fixed safety guards and safety signs in place.
D-1	Low	Only a trained operator to operate the machine.	Fixed safety guards and safety signs in place.
F-1C	Low	Read and understand operators manual.	Only a trained operator to operate the machine. No personnel near machine when operating.
G-1	Low	Read and understand operators manual.	Regular maintenance & daily checks to be carried out.
J-1A	Low	Operator is always seated in the tractor when the machine is operating.	Only a trained operator to operate the machine.

8.4 Hazard Identification

Be aware that it has arrears that can cause bodily harm or death if these safety precautions are not followed. As with any powered piece of machinery, ALWAYS TURN OFF POWER TO THE DEVICE PRIOR TO APPROACHING IT, SERVICING IT, OR ANY OTHER PROCESS WHICH MAY ALLOW AN INDIVIDUAL TO COME IN CONTACT WITH ANY PART OF IT. This will help ensure your safety and the safety of those around you.

Following is a list of areas which have been identified as a potential hazard and the type of hazard that could occur. This list is organized in order from front to rear of the machine.

8.4.1 Hitch Point



Hitch Point

The hitch area pivots as the machine is being moved through the field. There is a potential pinch point at this pivot primarily for the fingers or hands. Stay away from this hitch point while the machine is in motion.

8.4.2 Feed Chain

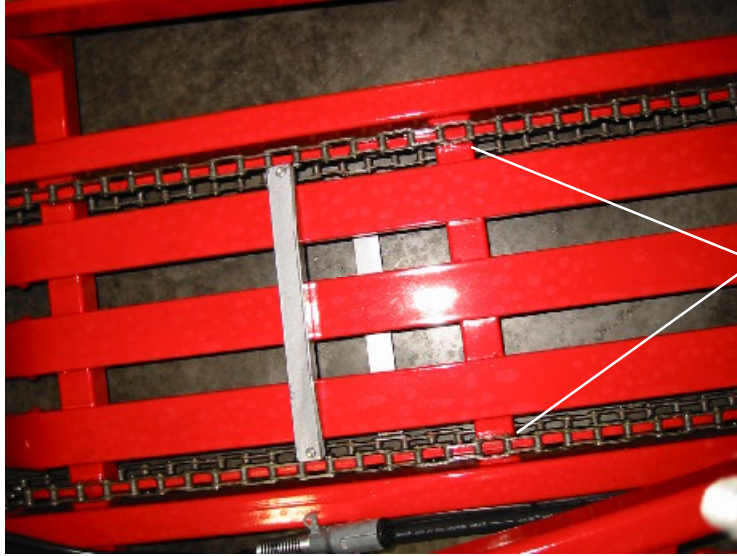

Feed Chains

On the front edge of the feed chain, two idler sprockets are located, one on either side of the frame. Either of these have a pinch point as the chain passes through them. On the rear edge of the feed chain, two drive sprockets are located. These also have a pinch point where the chain passes. The chain itself has three paddles, which force the bales into the machine. As these paddles come around the leading edge of the center frame, there is a serious pinch point in which there is an opening which gets smaller as the paddles progress. Keep all body parts, especially fingers and feet away from these areas anytime the machine has power to it or is moving.

8.4.3 Feed Motor

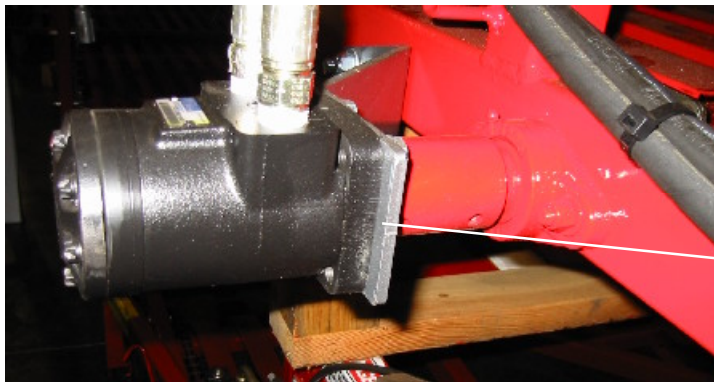

Feed Motor

The feed motor is located in front of the tire on the control side of the machine. There is a danger point as the shaft rotates. Keep away from this shaft to avoid injury.

8.4.4 Tie Arm



Tie Arm

This arm is the lower of the two powered arms, which place the bales into their positions. There are two potential hazard areas. The first is a pinch point when the arm is retracted. There are several areas along the length of the arm which have limited clearance between the arm and the frame. Any of these areas could be a potential pinch point.

8.4.5 Hydraulic Cylinder



Hydraulic Cylinder

The hydraulic cylinder which drives this arm also creates two potential pinch points as it pivots. Also, as the arm moves during its operation any contact with the bar at that time could result in bodily injury.

8.4.6 Push Arm

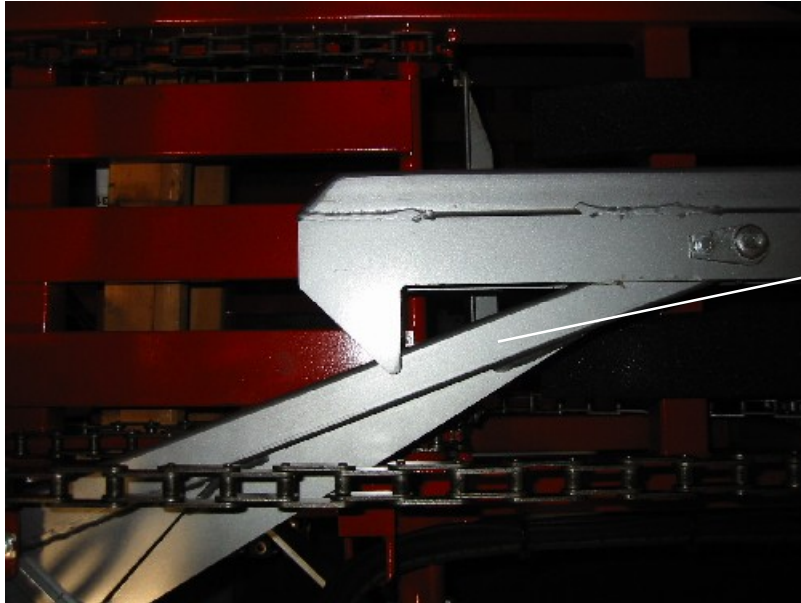

Push Arm

The push arm has a pair of links which pivot as the push arm is being moved. These create four specific pinch points, one located at each pivot. Do not come in contact with any of these points any time the machine is operating.

8.4.7 Hydraulic Cylinder

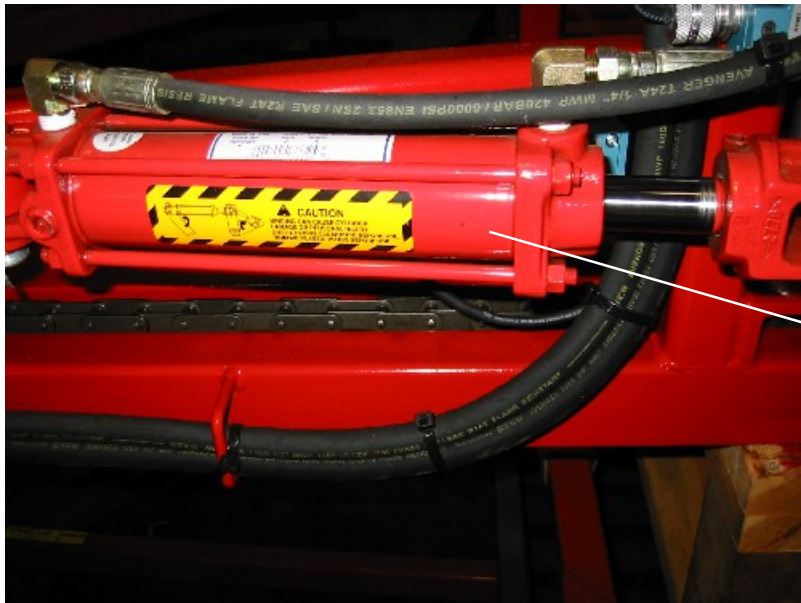

Hydraulic Cylinder

The hydraulic cylinder which powers this arm also has pinch points located at its pivots.

8.4.8 Retracting Push Arm



Retracting
Push Arm

Other potential pinch points on this arm are located at the front corner as it approaches the frame during full extension, and as the arm retracts, the tapered bale guide at the front edge of the arm could also create a pinching hazard. There is a potential crushing hazard as this arm activates. **THIS ARM IS POWERFUL ENOUGH TO INJURE.**

8.4.9 Dump Clutch



Dump Clutch

The dump clutch is the large sprocket located on the drive wheel . During the dump cycle this sprocket engages toward the tire. This creates a potential crush point between the tire and the sprocket.

8.4.9 Drive Chain

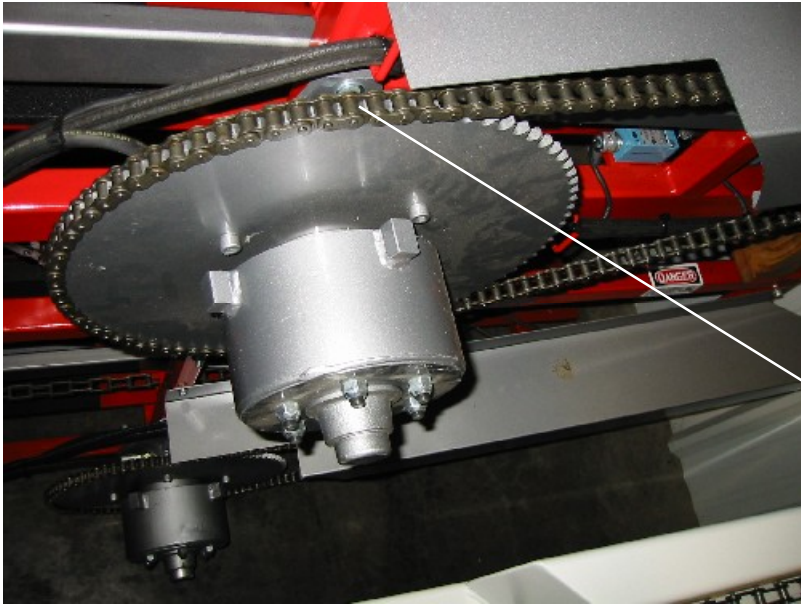

Drive Chain

The drive chain is located between the tire and the dump shaft. As with any powered chain, there are potential pinch points located at any point at which the chain comes in contact with the sprockets. The plastic chain tensioner also creates a potential pinch point as it can move during the chain operation.

8.4.10 Dump Chains



Dump Chains

There are two dump chains, one located on each side of the machine. They are connected to the two dump bars, which propel the finished package out of the machine. These chains move only when the machine is moving, but are powerful. Each of these chains has six sprockets, and one guide all which have potential pinch points as the chain passes through them.

8.4.11 Dump Bar

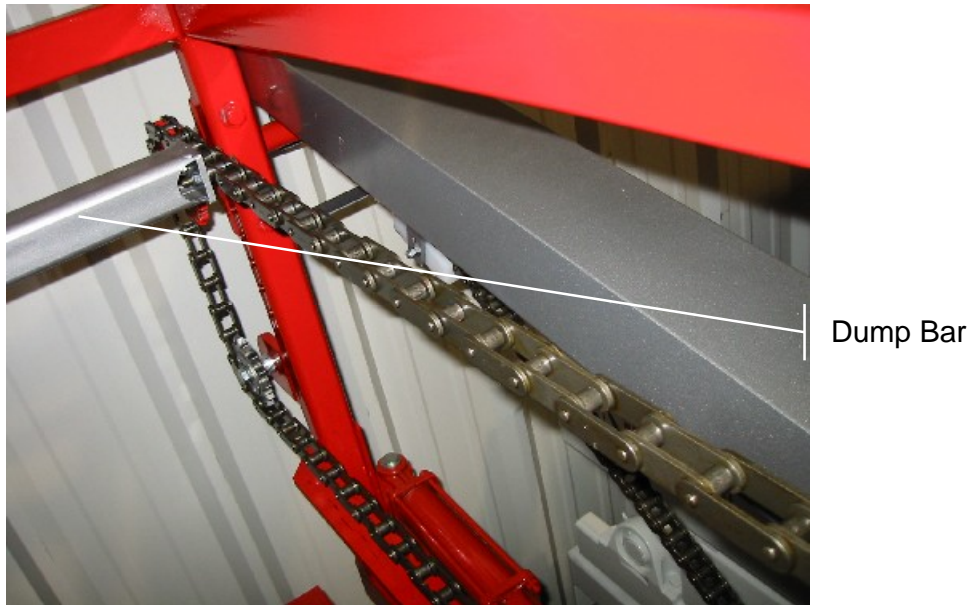

The dump bars can create a crush point as they pass near any of the frame structure while moving.

8.4.12 Tires

The tires are rolling as the machine is moving through the paddock. Take caution to stay away from them as they move. Potential crushing could occur if any body parts were trapped under them.

9. MACHINE SAFETY REVISION.

10. TRAINING NOTES

11. APPENDICES